

VC-412

Industrial VDSL2 Bridge with DIP Switch

USER'S MANUAL

Copyright

Copyright © 2012 by RubyTech Deutschland GmbH. All rights reserved.

Legal Disclaimer

The information given in this document shall in no event be regarded as a guarantee of conditions or characteristics. With respect to any examples or hints given herein, any typical values stated herein and/or any information regarding the application of the device, RubyTech Deutschland GmbH hereby disclaims any and all warranties and liabilities of any kind, including without limitation warranties of non-infringement of intellectual property rights of any third party.

Statement of Conditions

In the interest of improving internal design, operational function, and/or reliability, RubyTech reserves the right to make changes to the products described in this document without notice. RubyTech does not assume any liability that may occur due to the use or application of the product(s) or circuit layout(s) described herein.

Maximum signal rate derived from IEEE Standard specifications. Actual data throughput will vary. Network conditions and environmental factors, including volume of network traffic, building materials and construction, and network overhead lower actual data throughput rate. RubyTech does not warrant that the hardware will work properly in all environments and applications, and makes no warranty and representation, either implied or expressed, with respect to the quality, performance, merchantability, or fitness for a particular purpose. Make sure you follow in line with the environmental conditions to use this product.

Foreword: VDSL2 for industrial-grade solution

Attention:

Be sure to read this manual carefully before using this product. Especially Legal Disclaimer, Statement of Conditions and Safty Warnings.

RubyTech' VC-412 is a VDSL2 single port bridge equipped with four 10/100Mbps Ethernet ports that provide an economical solution for your industrial applications. Compliant with ITU-T G.993.2 VDSL2 standard, the VC-412 supports a maximum bandwidth of up to 100Mbps symmetric in VDSL2 Profile (30a) solution. The VC-412 also supports both central office (CO) and customer-premises equipment (CPE) modes selectable through DIP Switch.

The VC-412 use DIN-Rail and Industrial-grade design compliant with quick, easy, economical, and high-performance broadband/multimedia services to industrial environments such as Factory, MRT, Train station, Ticket vending machine, Parking system, Monitoring system and point to point applications.

Caution:

The VC-412 is for **indoor** applications only. It can be used in industrial-grade applications. This product does not have waterproof protection, please do not used in outdoor applications directly.

Safety Warnings

For your safety, be sure to read and follow all warning notices and instructions before device use.

- ◆ **DO NOT** open the device or unit. Opening or removing covers can expose you to dangerous high voltage points or other risks. ONLY qualified service personnel can service the device. Please contact your vendor for further information.
- ◆ **Use ONLY** the dedicated power supply for your device. Connect the power to the right supply voltage (110V AC used for North America and 230V AC used for Europe. VC-412 support 12~48 VDC dual power input (Redundant power).
- ◆ **Place** connecting cables carefully so that no one will step on them or stumble over them. DO NOT allow anything to rest on the power cord and do NOT locate the product where anyone can work on the power cord.
- ◆ **DO NOT** install nor use your device during a thunderstorm. There may be a remote risk of electric shock from lightning.
- ◆ **DO NOT** expose your device to dampness, dust or corrosive liquids.
- ◆ **DO NOT** use this product near water, for example, in a wet basement or near a swimming pool.
- ◆ **Connect ONLY** suitable accessories to the device.
- ◆ **Make sure** to connect the cables to the correct ports.
- ◆ **DO NOT** obstruct the device ventilation slots, as insufficient air flow may harm your device.
- ◆ **DO NOT** store things on the device.
- ◆ **DO NOT** use the device for outdoor applications directly, and make sure all the connections are indoors or have waterproof protection place.
- ◆ **Be careful** when unplugging the power, because may produce sparks.
- ◆ **Keep** the device and all its parts and accessories out of children's reach.
- ◆ **Clean** the device using a soft and dry cloth rather than liquid or atomizers. Power off the equipment before cleaning it.
- ◆ This product is **recyclable**. Dispose of it properly.

TABLE OF CONTENTS

COPYRIGHT 1

FOREWORD: VDSL2 FOR INDUSTRIAL-GRADE SOLUTION 2

SAFETY WARNINGS 3

CHAPTER 1. UNPACKING INFORMATION 6

1.1 Check List 6

CHAPTER 2. INSTALLING THE BRIDGE 7

2.1 Hardware Installation..... 7

2.2 Pre-installation Requirements 7

2.3 General Rules 8

2.4 Connecting the Bridge..... 8

2.5 Terminal Block and DIN-Rail mount installation..... 9

2.6 Connecting the RJ-11 / RJ-45 Ports 10

RubyTech VC-412 Industrial VDSL2 Bridge with DIP Switch USER'S MANUAL Ver. A3

2.7 Industrial VDSL2 bridge Application	12
CHAPTER 3: HARDWARE DESCRIPTION	14
3.1 Front Panel.....	15
3.2 Front Indicators	20
3.3 Rear Panel	21
3.4 Side Panel	21
APPENDIX A: CABLE REQUIREMENTS	26
APPENDIX B: PRODUCT SPECIFICATION	28
APPENDIX C: TROUBLESHOOTING	30
APPENDIX D: IP-30 PROTECTION OF METAL CASE	36
APPENDIX E: COMPLIANCE INFORMATION	38
WARRANTY.....	41

CHAPTER 1. UNPACKING INFORMATION

1.1 Check List

Carefully unpack the package and check its contents against the checklist.

Package Contents:



RJ-11



RJ-45



1 x Industrial Grade VDSL2 Bridge

Accessory Kit : 1 x DIN-Rail mounting plate, 2 x screws, 4 x Feet, Protective caps (RJ-11*1, RJ-45*3), 1 x 6pin Terminal Block, 1 x 2pin Terminal Block

Notes:

1. Please inform your dealer immediately for any missing or damaged parts. If possible, retain the carton including the original packing materials. Use them to repack the unit in case there is a need to return for repair.
2. Please using protective caps for unused ports.

Chapter 2. Installing the Bridge

2.1 Hardware Installation

This chapter describes how to install the bridge and establishes network connections and may install the bridge on any level surface (e.g. a table or shelf or rail). However, please take note of the following minimum site requirements before one begin.

2.2 Pre-installation Requirements

Before you start the actual hardware installation, make sure you can provide the right operating environment, including power requirements, sufficient physical space, and proximity to other network devices that are to be connected.

Verify the following installation requirements:

- Power requirements: **DC 12 to 48VDC redundant power.**
- The bridge should be located in a cool dry place, with at least **10cm/4in** of space at the front and back for ventilation.
- Place the bridge away from direct sunlight, heat sources, or areas with a high amount of electromagnetic interference.
- Check if the network cables and connectors needed for installation are available.
- **Do Not install phone lines strapped together with AC power lines, or telephone office line with voice signal.**
- **Avoid installing this device radio amplifying station nearby or transformer station nearby.**

2.3 General Rules

Before making any connections to the bridge, please note the following rules:

- **Ethernet Port (RJ-45)**

All network connections to the bridge Ethernet port must be made using Category 5 UTP or above for 100Mbps, Category 3, 4 UTP for 10Mbps.

No more than 100 meters of cabling may be use between the MUX or HUB and an end node.

- **VDSL2 Port (RJ-11)**

All network connections to the RJ-11port must use **24~26** gauge with **twisted pair** phone wiring.

We **do not recommend** the use of the telephone line 28 gauge or above.

2.4 Connecting the Bridge

The bridge has four Ethernet port which support connection to Ethernet operation. The devices attached to these ports must support auto-negotiation or 10Base-T OR 100Base-TX unless they will always operate at half duplex. Use any of the Ethernet ports to connect to devices such as Monitor system, Server, Switch, bridge or router.

Note:

1. The RJ11 Line port is used to connect to telephone that is connected to VDSL CO and CPE bridge (Point-to-point solution).
2. Unused RJ-45 ports(Ethernet Ports), please use protective cap to avoid dust intrusion.
3. Slave device (CPE) must connect Master device (CO) through the telephone wire. Slave cannot connect to Slave, and Master cannot connect to Master. Please confirm the DIP switch status before the link established.

2.5 Terminal Block and DIN-Rail mount installation

This section describes how to install the Terminal Block and DIN-Rail to the bridge, if you do not installation the DIN-Rail, please stick the 4 rubber feet at the bottom to avoid scratches.

- ◆ Take out the “2pin / 6pin terminal block” from inside the accessory kit, and install to the bridge properly. (Figure 2-1)
- ◆ Please refer to install the DIN-RAIL as following step:
 1. Install the DIN-Rail mounting plate to the VC-412. (Figure 2-2)
 2. Please use the suitable DIN-Rail to install, please refer to the dimensions of the DIN-Rail.(Figure 2-3)
 3. Insert the top of the DIN-Rail into the top slots on the DIN-Rail mounting plate and the DIN-Rail mounting plate will snap into place. (Figure 2-4)

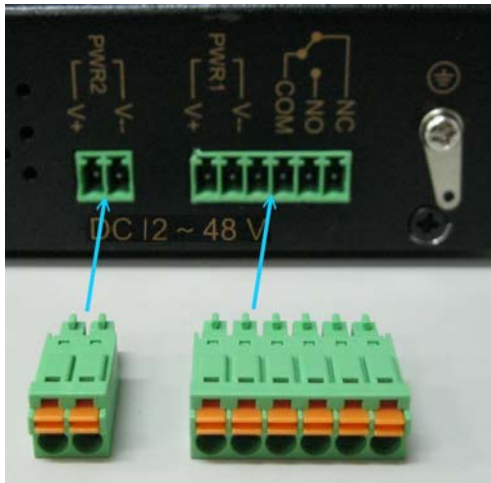

Figure 2-1

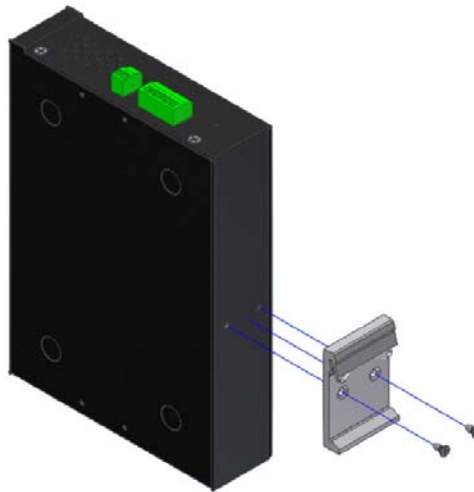

Figure 2-2

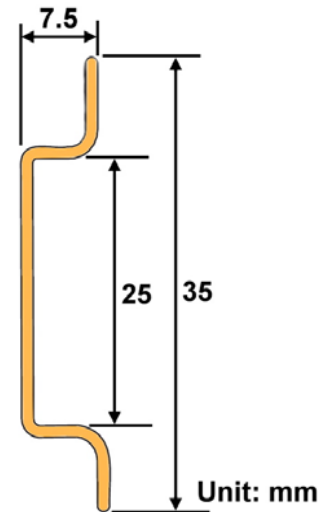

Figure 2-3

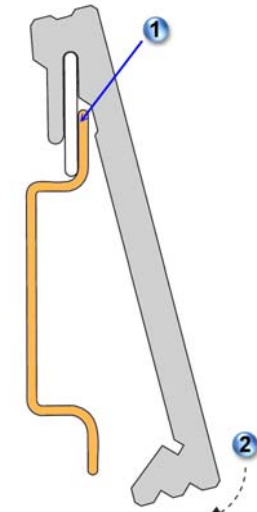

Figure 2-4

2.6 Connecting the RJ-11 / RJ-45 Ports

- ◆ The line port has 2 connectors: RJ-45 and terminal block. It is used to connect from VC-412 (CO) using single pair phone cable to VC-412 (CPE) bridge side (point to point solution). Take note that VC-412 line port cannot be used at the same time. Either RJ-11 port is connected or terminal block is connected using straight connection (Figure 2.4) or cross-over connection (Figure 2.5)

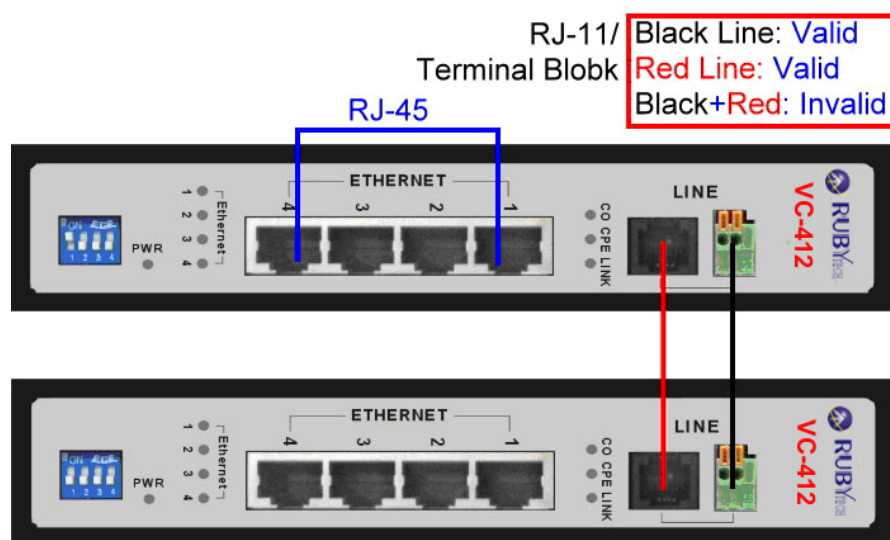

Figure 2.4 VC-412 line ports straight connection

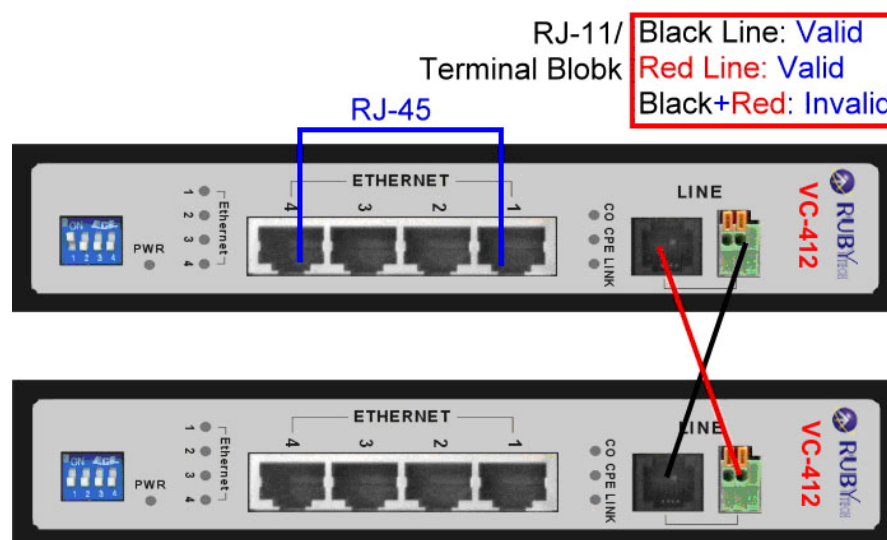

Figure 2.5 VC-412 line ports crossover connection

- ◆ When inserting a RJ-11 plug, make sure the tab on the plug clicks into position to ensure that it is properly seated.
- ◆ **Do not** plug a RJ-11 phone jack connector into the Ethernet port (RJ-45 port). This may damage the bridge. Instead, use only twisted-pair cables with RJ-45 connectors that conform to Ethernet standard.

Notes:

RubyTech VC-412 Industrial VDSL2 Bridge with DIP Switch USER'S MANUAL Ver. A3

1. Be sure each twisted-pair cable (RJ-45 ethernet cable) does not exceed 100 meters (333 feet).
2. We advise using Category 5~7 UTP/STP cables for Cable bridge or Bridge connections to avoid any confusion or inconvenience in the future when you attached to high bandwidth devices.
3. RJ-11(VDSL2 Line port) use **24 ~ 26** gauge with twisted pair phone wiring, we do not recommend 28 gauge or above.
4. Be sure phone wire has been installed before VC-412 powered on.

2.7 Industrial VDSL2 bridge Application

The bridge's line port supports 100Mbps for data service across existing phone wiring. It is easy-to-use which do not require installation of additional wiring. Every modular phone jack in the home can become a port on the LAN. Networking devices can be installed on a single telephone wire that can installation within suitable distance (depends on speed) (Figure 2.6)

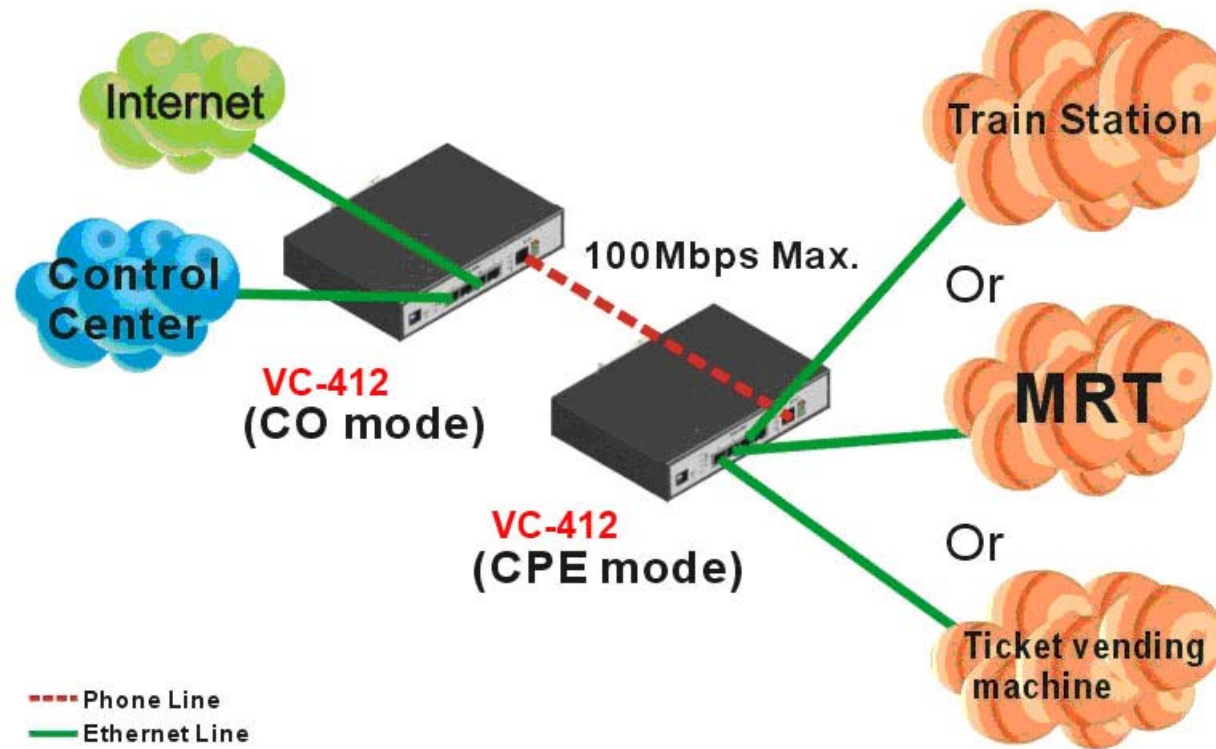

Figure 2.6 VC-412 point to point application

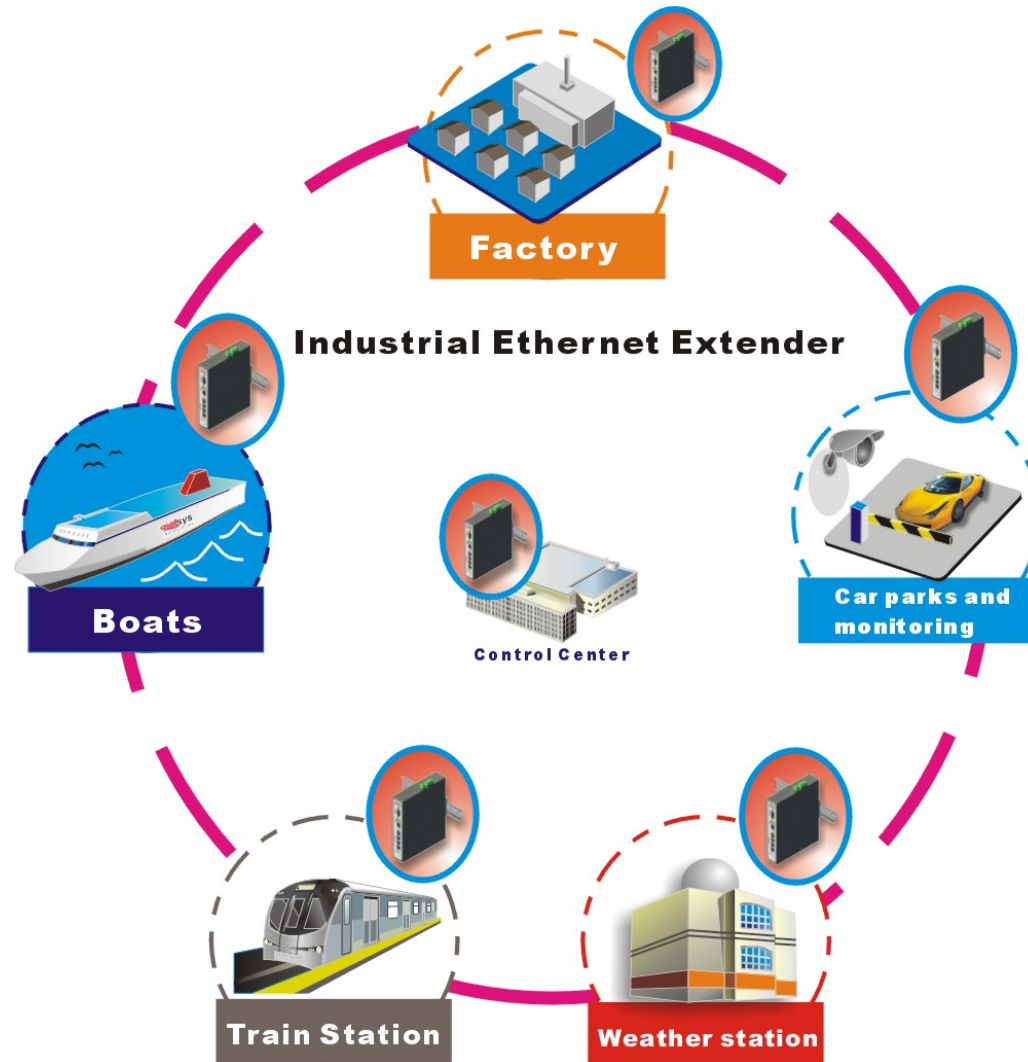

Figure 2.7 VC-412 industrial-grade application

Chapter 3. Hardware Description

This section describes the important parts of the bridge. It features the front panel, side panel and rear panel.



VC-412 Outward

3.1 Front Panel

The figure shows the front panel. (Figure 3.1)

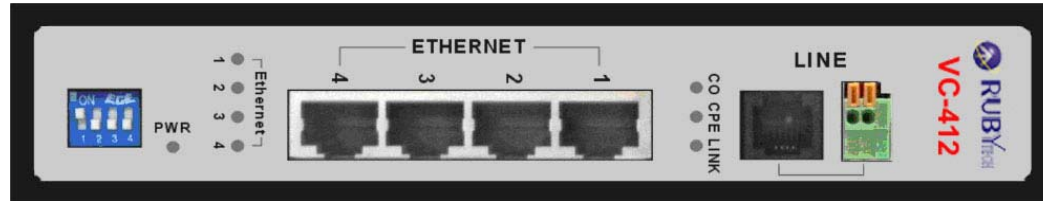

Figure 3.1 Front Panel

Tip:

At a quick glance of the front panel, it is easy to tell if it has Ethernet signal from its RJ-45 port and if there is vdsl line signal on RJ-11 port.

And the table shows the description. (Table 3-1)

Table 3-1 Description of the bridge front connectors

Connectors	Type	Description
DIP Switch	4 Pins DIP Switch	Provide 4 selectable transmission modes.
Ethernet	RJ-45	For connecting to a Ethernet equipped device.
Line	RJ-11/Terminal Block	For connecting to VDSL2 bridge. (Do not use RJ11 and Terminal Block at the same time.)

The following figure shows the DIP switch connection. By switching the transmission modes, you can obtain a best transmission mode to suit with phone line quality or distance or connectivity. (Figure 3.2)

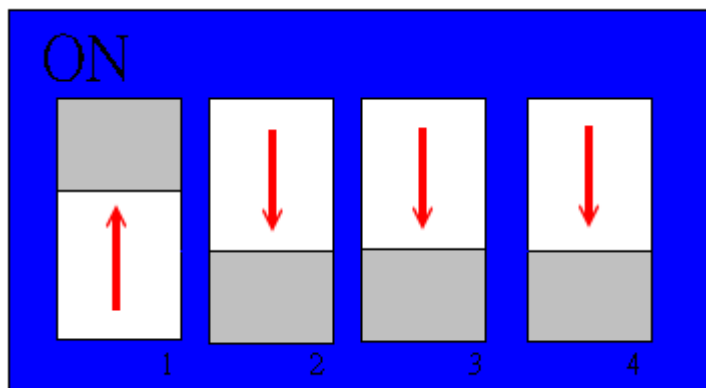

Figure 3.2 DIP switch setting

The following is summary table of transmission setting, bandwidth and distance extensibility tested for AWG 24 twisted-pair without noise and cross talk.([Table 3-2](#))

Table 3-2 DIP Switch Configuration

On/OFF	Pin 1	Pin 2	Pin 3	Pin 4
	CO/CPE Mode	Spectrum	SNR	Interleave / INP
On	CO Mode	500K~30MHz	9db	8ms / INP=2
Off	CPE Mode	25K~30MHz	6db	1ms / INP=0

RubyTech VC-412 Industrial VDSL2 Bridge with DIP Switch USER'S MANUAL Ver. A3

Note:

1. The DIP switch default value are OFF.
2. Please power off VC-412, before making any transmission mode adjustment.

◆ PIN1:

ON: CO (Central Office) Mode, usually the CO device will be located at the data enter of enterprise to link to the backbone.

OFF: CPE (Customer Premises Equipment) Mode, usually the CPE side will be located at factory, weather station, train station as the long reach data receiver.

Tip:

When the VC-412 operates at **CPE** mode, the DIP switch 2, 3, 4 is **no function**.

◆ PIN2:

ON: Spectrum mode(500KHz to 30MHz), and enable VDSL2 spectrum is 500KHz to 30MHz. It can pass through **ISDN** spectrum(0 ~ 499KHz are empty).

OFF: Spectrum mode(25KHz to 30MHz), the VC-412 will auto-detect the cable length and auto choice speed mode. VDSL2 spectrum is 25KHz to 30MHz.

◆ PIN3:

When SNR margin is selected, the system provide **6db/9db** SNR margin for across all usable loop length. Generally speaking, the higher SNR value gets better line quality, but low performance.

◆ PIN4:

RubyTech VC-412 Industrial VDSL2 Bridge with DIP Switch USER'S MANUAL Ver. A3

ON: Interleaved mode has a maximum end to end latency of **8m** sec and **INP=2**. When field environment has heavy noise, in order to obtain high link quality, user can adjust pin4 to "ON", but this function will **reduce performance**.

OFF: Interleaved mode provides impulse noise protection for any impulse noise with a duration less than **1ms**.

TIP:

Interleave delay function is used in digital data transmission technology to protect the transmission against noise issue and data error.

If during transit more than a certain amount of data has been lost then the data cannot be correctly decoded. Short bursts of noise on the line can cause these data packets to become corrupt and the bridge has to re-request data which in turn can slow down the overall rate at which data is transmitted.

Interleaving is a method of taking data packets, chopping them up into smaller bits and then rearranging them so that once contiguous data is now spaced further apart into a non continuous stream. Data packets are re-assembled by your bridge.

The diagram below is an example of how interleaved traffic is transmitted.

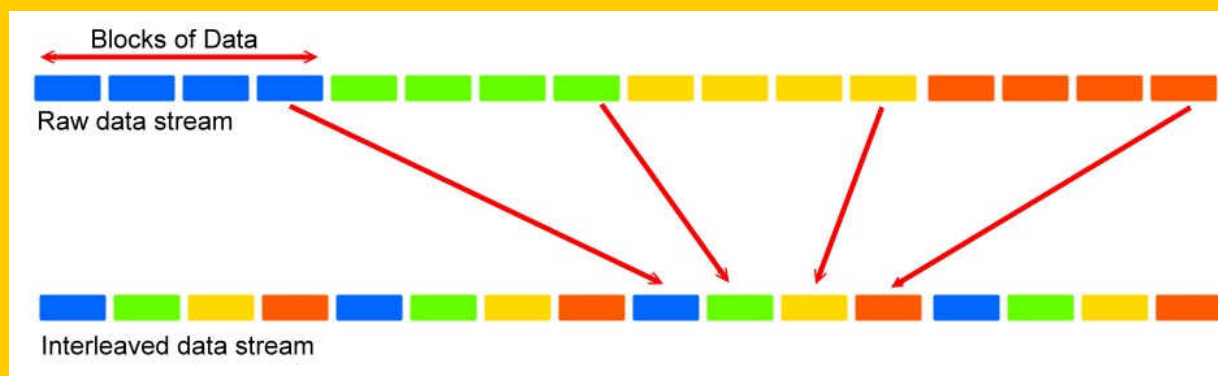

If your line is particularly susceptible to bursts of noise then interleaving should improve your VDSL2 experience simply because if you lose a whole batch of data then this could cause your bridge to lose sync with the exchange.

Using Interleaving, the bridge is able to re-assemble the data or if necessary just re-request the part of the data that it is unable to recover. By increasing the interleave depth of each ports that are susceptible to noise, this will improve error performance and stability of marginal lines.

INP(Impulse Noise Protection): Impulse noise in multicarrier communication systems behaves effectively as a modulating signal that controls the first moment of the background Gaussian noise. The composite noise, which is the aggregate of the Gaussian noise and impulse noise, has a probability density function that is conditionally Gaussian with non-zero average, hence referred to as biased-Gaussian. The BER-equivalent power of the composite noise source is defined as the power of a pure Gaussian noise source that yields the same bit-error rate (BER). The BER-equivalent noise for a biased-Gaussian noise is simply the amplified version of the underlying Gaussian noise source. The amplification factor is derived from the characteristics of the impulse interference. Any bit-loading algorithm designed for Gaussian noise sources is also applicable to biased-Gaussian noise sources provided that the BER-equivalent SNR is used in place of the measured SNR.

3.2 Front Indicators

The bridge has **Eight** LED indicators. The following Table shows the description. (Table 3-3)

Table 3-3 LED Indicators Description and Operation

LED	Color	Status	Descriptions
PWR (Power LED)	Green	On(Steady)	Lights to indicate that the VDSL2 bridge had power
		Off	The device is not ready or has malfunctioned.
ETHERNET 1-4 (Ethernet LED)	Green	On(Steady)	The device has a good Ethernet connection.
		Blinking	The device is sending or receiving data.
		Off	The LAN is not connected.
CO (CO LED)	Green	On(Steady)	Indicate the VDSL2 bridge is running at CO(Master) mode.
CPE (CPE LED)	Green	On(Steady)	Indicate the VDSL2 bridge is running at CPE(Slave) mode.
LINK (VDSL LED)	Green	On(Steady)	The Internet or network connection is up.
		Blinking slowly	The CO device is auto-detecting CPE device.
		Blinking fastly	1. The CO device has detected a CPE device and ready to connect. 2. The device is sending or receiving data.
		Off	The Internet or network connection is down or has malfunctioned.

Note:

Two Bridges connection may take within 3 minutes is normal, due to VC-412 to establish a link mechanism is auto-negotiation, with detects and calculate CO and CPE both PBO and PSD level as well as noise level ...and other argument etc. for getting a better connection.

3.3 Rear Panel

The following figure shows the rear panel. (Figure 3.3)



Figure 3.3 Rear Panel

Note:

Please refer to section 2.5 to install the DIN RAIL.

3.4 Side Panel

The following figure shows the side. (Figure 3.4)

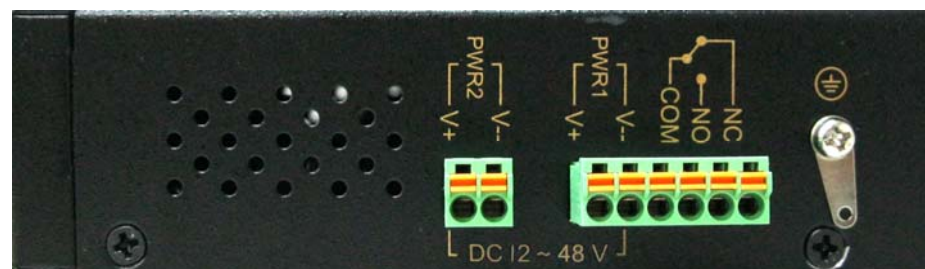
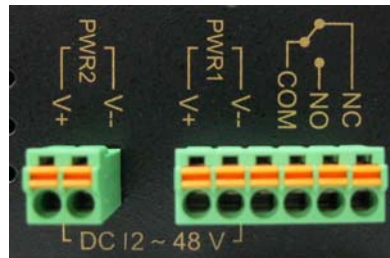

Figure 3.4 Rear connectors

The following description introduce Dual power and Relay Contact.

Wiring the dual Power Inputs

The VC-412 has two sets of power inputs, power 1 and power 2, which are located on the VC-412's side panel. Power 1 is the bottom two contacts on the upper 6-contact terminal block and power 2 is the top two contacts on the lower 2-contact terminal block.



STEP 1: Insert the negative/positive DC wires into the V-/V+ terminals, respectively.

STEP 2: Placed the the DC wires into terminal block connector: Push the orange switch of the terminal block with a small flat-blade screwdriver, then the DC wires insert the orange bottom of the circle hole, and release the small flat-blade screwdriver.

STEP 3: Insert the plastic terminal block connector prongs into the terminal block receptor, which is located on the VC-412's side panel.

Attention:

1. Please note that the negative DC wire must connect into the V- terminal, positive DC wire must connect V+terminal. If contrary to the location of the wiring, VC-412 will enable Reverse Polarity Protection function automatically. DC power will not be able to directly through the machine.
2. Please note that if the DC power current exceeds 3A, VC-412 will enable Overload Current Protection function automatically. DC power will not be able to directly through the machine.

Safety Caution!

1. **Be sure to disconnect the power when installing (uninstalling) the terminal block and power cable.**
2. **Please note that the user can use 12~48VDC dual power input (Redundant Power). Do not exceed DC 48V.**
3. **Be sure to disconnect the power before installing and/or wiring your VC-412 bridge.**
4. **Please calculate the maximum possible current in each power wire and common wire. Observe all electrical codes dictating the maximum current allowable for each wire size. If the current goes above the maximum ratings, the wiring could overheat, causing serious damage to your equipment.**

Power Input Status

The following Table shows the examples of the power input status. (Table 3-4)

Table 3-4

		Example 1				Example 2				Example 3			
Power Item	Default Polarity	Power Input1	Output State1	Power Input2	Output State2	Power Input1	Output State1	Power Input2	Output State2	Power Input1	Output State1	Power Input2	Output State2
Power 1	-	12V-	OFF	12V-	ON	12V+	Protection	12V+	Protection	48V-	ON	No Power	OFF
	+	12V+		12V+		12V-		48V+					
Power 2	-	24V-	ON	No Power	OFF	24V-	ON	No Power	OFF	48V-	ON	48V-	ON
	+	24V+				24V+				48V+		48V+	

		Example 4				Example 5				Example 6			
Power Item	Default Polarity	Power Input1	Output State1	Power Input2	Output State2	Power Input1	Output State1	Power Input2	Output State2	Power Input1	Output State1	Power Input2	Output State2
Power 1	-	12V-	Malfunction	12V-	Malfunction	12V-	ON	12V-	Malfunction	48V-	ON	No Power	OFF
	+	12V+		12V+		12V+		48V+					
Power 2	-	60V-	Malfunction	No Power	Malfunction	No Power	OFF	60V-	Malfunction	48V+	Protection	48V+	Protection
	+	60V+						60V+		48V-		48V-	

Notes:

1. State 1 always happens before state 2.
2. Protection means enable Reverse Polarity Protection function.
3. Please note that if use different DC voltage, higher voltage will feeding to VC-412.
4. Please note warranty is void if exceed DC 48V.

Wiring the Relay Contact

The VC-412 has a set of relay outputs. The relay contact uses two of the terminal block's contacts located on the VC-412's side panel. Refer to the following table shows how to connect the wires to the terminal block connector. In this section, we illustrate the meaning of the two contacts used to connect the relay contact.

Fault Tip:

The relay contacts of the 6-pin terminal block connector are used to detect user-configured events. The three wires attached to the fault contacts form an open circuit when a user-configured event is triggered. If a user-configured event does not occur, the fault circuit remains closed. The relay output has current carrying capacity of 1 A @ 24 VDC.

The following Table shows the Relay circuit and power status. (Table 3-5)

Table 3-5 Relay Circuit Status and Power ON/OFF Status.

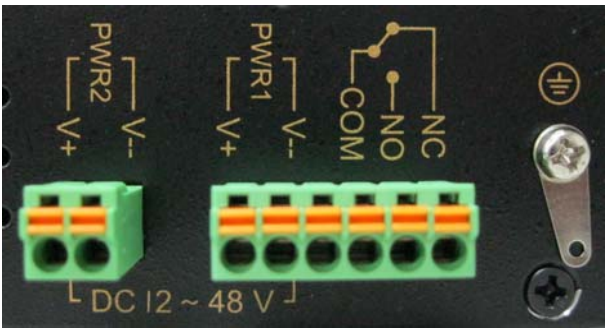
	Power ON	COM & NC	Open Circuit
		COM & NO	Short Circuit
	Power OFF	COM & NC	Short Circuit
		COM & NO	Open Circuit

Grounding the VC-412

VC-412 is designed to enhance EMS performance by grounding. VC-412 come with metal DIN-Rail brackets for grounding the switches. For optimal EMS performance, connection of the right of the VC-412 side panel ground lug to the grounding point.

Before user installed power and device, please read and follow these essentials:

- ◆ Use separate paths to route wiring for power and devices. If power wiring and device wiring paths must cross, make sure the wires are perpendicular at the intersection point.

Note:

Do not run signal or communications wiring and power wiring through the same wire conduit. To avoid interference, wires with different signal characteristics should be routed separately.

- ◆ You can use the type of signal transmitted through a wire to determine which wires should be kept separate. The rule of thumb is that wiring sharing similar electrical characteristics can be bundled together.
- ◆ You should separate input wiring from output wiring.
- ◆ We recommend that you mark all equipment in the wiring system.

Appendix A: Cable Requirements

Ethernet Cable

A CAT 3~7 UTP (unshielded twisted pair) cable is typically used to connect the Ethernet device to the bridge. A 10Base-T cable often consists of four pairs of wires, two of which are used for transmission. The connector at the end of the 10Base-T cable is referred to as an RJ-45 connector and it consists of eight pins. The Ethernet standard uses pins 1, 2, 3 and 6 for data transmission purposes. (Table A-1)

Table A-1 RJ-45 Ethernet Connector Pin Assignments

PIN #	MDI		MDI-X	
	Signal	Media Dependant interface	Signal	Media Dependant interface-cross
1	TX+	Transmit Data +	RX+	Receive Data +
2	TX-	Transmit Data -	RX-	Receive Data -
3	RX+	Receive Data +	TX+	Transmit Data +
4	--	Unused	--	Unused
5	--	Unused	--	Unused
6	RX-	Receive Data -	TX-	Transmit Data -
7	--	Unused	--	Unused
8	--	Unused	--	Unused

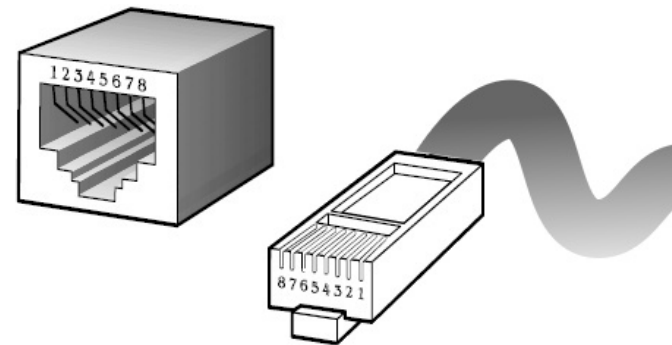

Figure A-1 Standard RJ-45 repectacle/connector

Note:

Please make sure your connected cables are with same pin assignment as above table before deploying the cables into your network.

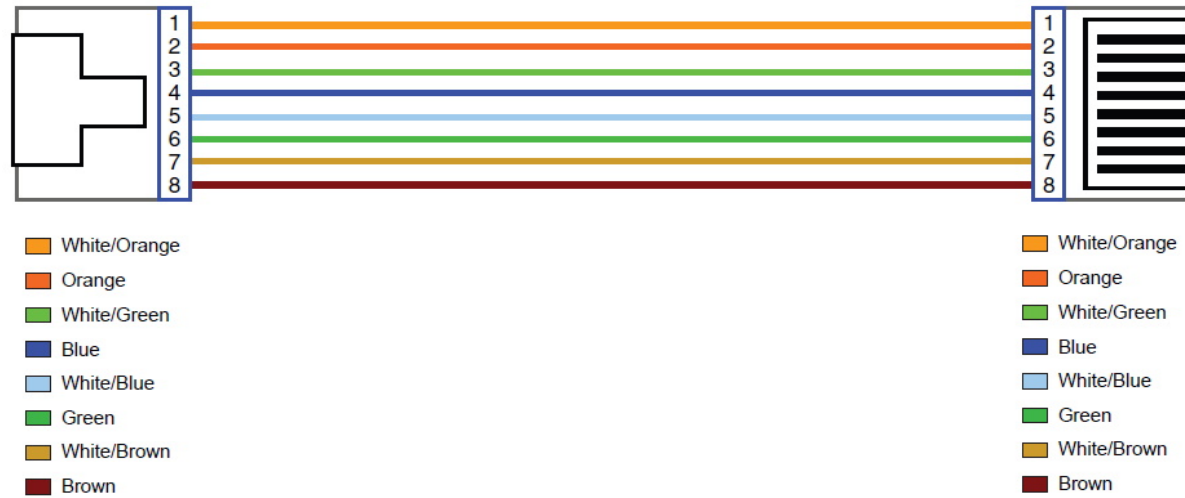

Figure A-2 Pin Assignments and Wiring for an RJ-45 Straight-Through Cable

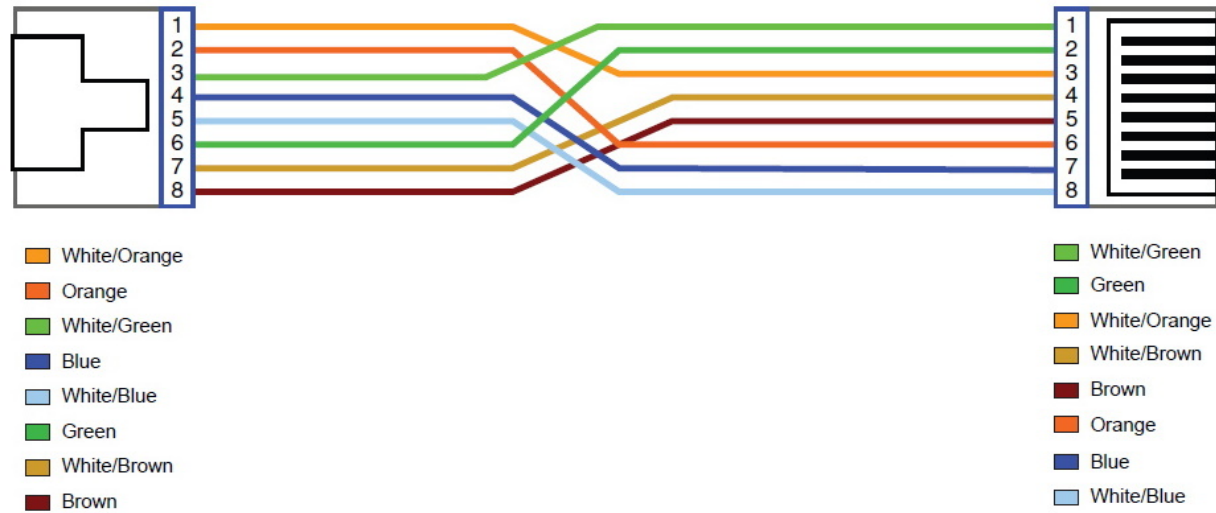

Figure A-3 Pin Assignments and Wiring for an RJ-45 Crossover Cable

Appendix B: Product Specification

Key Features & Benefits

- Supports high bandwidth up to 100Mbps symmetric over Line ports
- Support long reach mode up to 3 km with 24 gauge phone wire
- Support auto speed for Line port and Interleave mode selectable through CO side DIP switch
- DIP switch with CO and CPE mode selectable
- Supports long packet size up to 1536 bytes
- Supports Surge protection
- Support power redundant and wide range dual power input(DC12V ~ 48V)
- Supports Overload Current Protection
- Supports wide range operating temperature(-20°C ~ 70°C)
- Supports Reverse Polarity Protection
- Supports alarm contact (relay output - 1 A @ 24 VDC)
- Supports DIN-Rail mount installation
- Metal case design and compliant with IP30 standard

Product Specification

Standard:	IEEE802.3 / IEEE802.3u standard G993.2 VDSL2 standard
------------------	--

RubyTech VC-412 Industrial VDSL2 Bridge with DIP Switch USER'S MANUAL Ver. A3

Physical Interface:	4 * RJ-45 10/100Mbps Ethernet port 1 * RJ-11/Terminal Block connector for VDSL2 line port 1 * DIP Switch 1 * removable 6-contact terminal blocks for power1 and alarm contact 1 * removable 2-contact terminal blocks for power2
LED Indicators:	1 * Power LED 4 * Link/Active Status for Ethernet port 1 * Link/Speed for VDSL2 port 1 * CO Mode indicator LED 1 * CPE Mode Indicator LED
VDSL2 Line Code:	Discrete multitone (DMT) modulation
VDSL 2Transmission Mode:	Packet Transfer Mode (PTM)
Typical Power Consumption:	6 W
Power Input:	Input Voltage: 12 to 48VDC Input Current: 0.5~0.125A
EMC:	EMI Compliant: FCC class A EMS Compliant: CE mark
Operating Temperature:	-20°C ~ 70°C (-4°F ~ 158°F) Fanless, free air cooling
Storage Temperature:	-40°C ~ 70°C (-40°F ~158°F)
Humidity:	5% to 95% (non-condensing)
Weight:	About 0.63 kg
Dimensions:	170 x 121 x 35 mm (6.7" x 4.76" x 1.37")

Appendix C: Troubleshooting

Diagnosing the Bridge's Indicators

The bridge can be easily monitored through its comprehensive panel indicators. These indicators assist the network manager in identifying problems the hub may encounter. This section describes common problems you may encounter and possible solutions.

1. Symptom:	POWER indicator does not light up (green) after power on.
Cause:	Defective External power supply
Solution:	Check the power plug by plugging in another that is functioning properly. Check the power cord with another device. Check the terminal block make sure to fasten the power cord. If these measures fail to resolve the problem, have the unit power supply replaced by a qualified distributor.
Note:	Please refer to power status table to check power input status. Section 3.4
2. Symptom:	Link indicator does not light up (green) after making a connection.
Cause:	Network interface (ex. a network adapter card on the attached device), network cable, or switch port is defective.
Solution:	<ol style="list-style-type: none">2.1 Power off and re-power on the VDSL bridge.2.2 Verify that the switch and attached device are power on.2.3 Be sure the cable is plugged into both the switch and corresponding device.2.4 Verify that the proper cable type is used and its length does not exceed specified limits.2.5 Check the bridge on the attached device and cable connections for possible defects.2.6 Make sure that the phone wire must be connecting VC-412 first, when powered on.2.7 Replace the defective bridge or cable if necessary.

RubyTech VC-412 Industrial VDSL2 Bridge with DIP Switch USER'S MANUAL Ver. A3

3. Symptom:	VDSL Link cannot be established.
Cause:	VDSL setting failure or phone cable length is over the specification limit.
Solution:	<p>3.1 Please make sure that the phone wire must be connected between VC-412 (CO) and VC-412 (CPE) when both are power on. VC-412 (CO) will do link speed function depending on phone wire length, therefore if VC-412 (CO) can't detect VC-412 (CPE) over phone wire while both power on, this will cause the link to fail.</p> <p>3.2 Please check phone wire, we recommend use 24-26 gauge with twisted pair and without rust.</p> <p>3.3 Please check the correct Dip Switch setting.</p> <p>3.4 Please reinsert power when change cable length or link time over 3 minutes.</p>
Note:	Phone wire must meet CAT 3 standard or above and without clustering , otherwise will cause more cross talk issue to reduce DSL power driver.
4. Problem:	What is VDSL2?
Answer:	<p>Very-high-speed digital subscriber line 2 (VDSL2) is an access technology that exploits the existing infrastructure of copper wires that were originally deployed for traditional telephone service. It can be deployed from central offices, from fiber-optic connected cabinets located near the customer premises, or within buildings. It was defined in standard ITU-T G.993.2 finalized in 2005.</p> <p>VDSL2 was the newest and most advanced standard of digital subscriber line (DSL) broadband wireline communications. Designed to support the wide deployment of triple play services such as voice, video, data, high definition television (HDTV) and interactive gaming, VDSL2 was intended to enable operators and carriers to gradually, flexibly, and cost-efficiently upgrade existing xDSL infrastructure.</p>

The protocol was standardized in the International Telecommunication Union telecommunications sector (ITU-T) as Recommendation G.993.2. It was announced as finalized on 27 May 2005,[1] and first published on 17 February 2006. Several corrections and amendments were published in 2007 through 2011.

VDSL2 is an enhancement to very-high-bitrate digital subscriber line (VDSL), Recommendation G.993.1. It permits the transmission of asymmetric and symmetric aggregate data rates up to 200 Mbit/s downstream and upstream on twisted pairs using a bandwidth up to 30 MHz.

VDSL2 deteriorates quickly from a theoretical maximum of 250 Mbit/s at source to 100 Mbit/s at 0.5 km (1,600 ft) and 50 Mbit/s at 1 km (3,300 ft), but degrades at a much slower rate from there, and still outperforms VDSL. Starting from 1.6 km (1 mi) its performance is equal to ADSL2+.

ADSL-like long reach performance is one of the key advantages of VDSL2. LR-VDSL2 enabled systems are capable of supporting speeds of around 1–4 Mbit/s (downstream) over distances of 4–5 km (2.5–3 miles), gradually increasing the bit rate up to symmetric 100 Mbit/s as loop-length shortens. This means that VDSL2-based systems, unlike VDSL1 systems, are not limited to short local loops or MTU/MDUs only, but can also be used for medium range applications.

5. Problem: What is SNR(Signal-to-Noise)

Answer:

Signal-to-noise ratio (often abbreviated SNR or S/N) is a measure used in science and engineering that compares the level of a desired signal to the level of background noise. It is defined as the ratio of signal power to the noise power. A ratio higher than 1:1 indicates more signal than noise. While

RubyTech VC-412 Industrial VDSL2 Bridge with DIP Switch USER'S MANUAL Ver. A3

SNR is commonly quoted for electrical signals, it can be applied to any form of signal (such as isotope levels in an ice core or biochemical signaling between cells). The ratio is usually measured in decibels(dB)

The signal-to-noise ratio, the bandwidth, and the channel capacity of a communication channel are connected by the Shannon–Hartley theorem.

In digital communications, the SNR will probably cause a reduction in data speed because of frequent errors that require the source (transmitting) computer or terminal to resend some packets of data. SNR measures the quality of a transmission channel over a network channel. The greater the ratio, the easier it is to identify and subsequently isolate and eliminate the source of noise.

System Diagnostics

Power and Cooling Problems

If the POWER indicator does not turn on when the power cord is plugged in, you may have a problem with the power outlet, power cord, or internal power supply as explained in the previous section. However, if the unit power is off after running for a while, check for loose power connections, power losses or surges at the power outlet. If you still cannot isolate the problem, then the internal power supply may be defective. In this case, please contact your local dealer.

Installation

Verify that all system components have been properly installed. If one or more components appear to be malfunctioning (e.g. the power cord or network cabling), test them in an alternate environment where you are sure that all the other components are functioning properly.

Transmission Mode

The default method of selecting the transmission mode for RJ-45 ports is 10/100 Mbps ETHERNET, for RJ-11 port are auto-negotiation VDSL. Therefore, if the Link signal is disrupted (e.g. by unplugging the network cable and plugging it back in again, or by resetting the power), the port will try to reestablish communications with the attached device via auto-negotiation. If auto-negotiation fails, then communications are set to half duplex by default. Based on this type of industry-standard connection policy, if you are using a full-duplex device that does not support auto-negotiation, communications can be easily lost (i.e. reset to the wrong mode) whenever the attached device is reset or experiences a power fluctuation. The best way to resolve this problem is to upgrade these devices to a version that support Ethernet and VDSL.

Physical Configuration

If problems occur after altering the network configuration, restore the original connections, and try to track the problem down by implementing the new changes, one step at a time. Ensure that cable distances and other physical aspects of the installation do not exceed recommendations.

System Integrity

As a last resort verify the switch integrity with a power-on reset. Turn the power to the switch off and then on several times. If the problem still persists and you have completed all the preceding diagnoses, then contact your dealer.

Appendix D: IP-30 protection of metal case

The term “protection class” generally indicates the type of protection of a device or the internal workings of a device against direct contact and against the infiltration of foreign bodies, such as objects, dust or water.

The resistance to stress arising from prevailing working conditions is defined using international protection (IP) classes. These protection classes are, in turn, indicated in IP standards (DIN EN 60529), whereby a combination of two digits specifies the level of protection. The first digit indicates the level of resistance to foreign bodies and dust, the second digit the level of resistance to water infiltration. A higher value of the relevant digit (first digit 0 – 6, second digit 0 - 8) indicates a higher level of protection.

The table on the following offers clarity and an overview of the IP rules:

Table D-1 First Digit: Protection grades for contact and foreign matter protection.

Digit	Designation	Explanation
0	No protection	No special protection to prevent infiltration by solid objects.
1	Protection against large foreign matter	Protection against solid objects greater than 50 millimeters in diameter.
2	Protection against mediumsized Foreign matter	Protection against solid objects greater than 12.5 millimeters in diameter.
3	Protection against small foreign matter	Protection against solid objects greater than 2.5 millimeters in diameter.
4	Protection against circular foreign matter	Protection against solid objects greater than 1 millimeter in diameter.
5	Dust protected	Complete protection against dust is not necessary, but infiltration must be prevented to a sufficiently high degree to ensure that the functioning and safety of the device are not impaired.
6	Dustproof	Complete protection against dust infiltration

RubyTech VC-412 Industrial VDSL2 Bridge with DIP Switch USER'S MANUAL Ver. A3

Table D-2 Second Digit: Protection grades for water protection.

Digit	Designation	Explanation
0	No protection	No special protection to prevent water infiltration.
1	Protection against vertically dripping water	Water dripping vertically on to the device may not have any harmful effect.
2	Protection against water dripping at an angle	Water dripping vertically onto a device tilted to an angle of up to 15° from the vertical may not have any harmful effect.
3	Protection against spray water	Protection against water sprayed at any angle up to 60° from the vertical on to the device.
4	Protection against splash water	Water splashing against the device from any direction may not have any harmful effect.
5	Protection against water jets	A jet of water aimed at the housing from any direction may not have any harmful effect.
6	Protection against strong water jets	A strong water jet aimed at the device from any direction may not have any harmful effect.
7	Protection against temporary immersion	When the device is immersed in water up to 1 meter from the lower edge of the device, water may not enter the device in any sufficient quantity to cause damage.
8	Protection against continuous immersion	The device is suitable for continuous immersion in water. The conditions must be individually agreed between the manufacturer and the user but must, at least, exceed the specification of digit 7.

Appendix E: Compliance Information

FCC Radio Frequency Interference Statement

This equipment has been tested and found to comply with the limits for a computing device, pursuant to Part 15 of FCC rules. These limits are designed to provide reasonable protection against harmful interference when the equipment is operated in a commercial environment. This equipment generates uses and can radiate radio frequency energy and, if not installed and used in accordance with the instructions, may cause harmful interference to radio communications. However, there is no guarantee that interference will not occur in a particular installation. If this equipment does cause harmful interference to radio or television reception, which can be determined by turning the equipment off and on, the user is encouraged to try to correct the interference by one or more of the following measures:

1. Reorient or relocate the receiving antenna.
2. Increase the separation between the equipment and receiver.
3. The equipment and the receiver should be connected to outlets on separate circuits.
4. Consult the dealer or an experienced radio/television technician for help.

Changes or modifications not expressly approved by the party responsible for compliance could void the user's authority to operate the equipment.

If this telephone equipment causes harm to the telephone network, the telephone company will notify you in advance that temporary discontinuance of service may be required. But if advance notice isn't practical, the telephone company will notify the customer as soon as possible. Also, you will be advised of your right to file a complaint with the FCC if you believe it is necessary.

The telephone company may make changes in its facilities, equipment, operations or procedures that could affect the

RubyTech VC-412 Industrial VDSL2 Bridge with DIP Switch USER'S MANUAL Ver. A3

proper functioning of your equipment. If they do, you will be notified in advance in order for you to make necessary modifications to maintain uninterrupted service.

This equipment may not be used on coin service provided by the telephone company. Connection to party lines is subject to state tariffs.

FCC Warning



This equipment has been tested to comply with the limits for a Class B digital device, pursuant to Part 15 of the FCC Rules. These limits are designed to provide reasonable protection against harmful interference when the equipment is operated in a commercial environment. This equipment can generate, use, and radiate radio frequency energy and, if not installed and used in accordance with the instruction manual, may cause harmful interference to radio communications. Operation of this equipment in a residential area is likely to cause harmful interference in which case the user will be required to correct the interference at owner's expense.

CE Mark Warning



This is a class B product. In a domestic environment, this product may cause radio interference in which case the user may be required to take adequate measures.

WEEE Warning



To avoid the potential effects on the environment and human health as a result of the presence of hazardous substances in electrical and electronic equipment, end users of electrical and electronic equipment should understand the meaning of the crossed-out wheeled bin symbol. Do not dispose of WEEE as unsorted municipal waste and have to collect such WEEE separately.

Warranty

The original owner that the product delivered in this package will be free from defects in material and workmanship for one year parts after purchase.

There will be a minimal charge to replace consumable components, such as fuses, power transformers, and mechanical cooling devices. The warranty will not apply to any products which have been subjected to any misuse, neglect or accidental damage, or which contain defects which are in any way attributable to improper installation or to alteration or repairs made or performed by any person not under control of the original owner.

The above warranty is in lieu of any other warranty, whether express, implied, or statutory, including but not limited to any warranty of merchantability, fitness for a particular purpose or any warranty arising out of any proposal, specification or sample. We shall not be liable for incidental or consequential damages. We neither assume nor authorize any person to assume for it any other liability.



WARNING:

DO NOT TEAR OFF OR REMOVE THE WARRANTY STICKER AS SHOWN, OR THE WARRANTY IS VOID.